

# SL1000EVK

800 N | for gates up to 1000 kg per leaf

POWERED BY  
myQ®

**Motor warranty: 2 years**

**Max. gate weight with max. leaf width**

1000 kg max. weight per leaf

12 m max. width per leaf\*

**Max. cycles h/day:** 10/30

**Max. opening speed:** 240mm/sec.

\* 2-leaf application via synchronisation possible.  
2nd Sliding gate drive required



## Delivery kit SL1000EVK

**SL1000EV**



**1 x 24 V sliding gate operator**

**TX4EVF**



**4-channel remote transmitter**  
Controls up to 4 openers

**041A0288**



**1 x control board**  
factory installed Includes  
transformer and integrated  
radio module

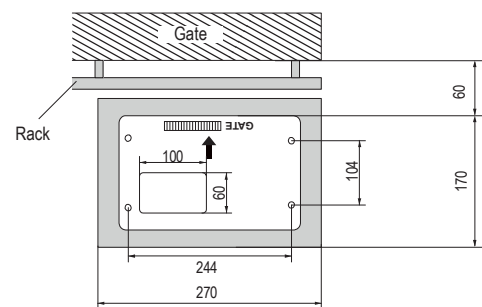
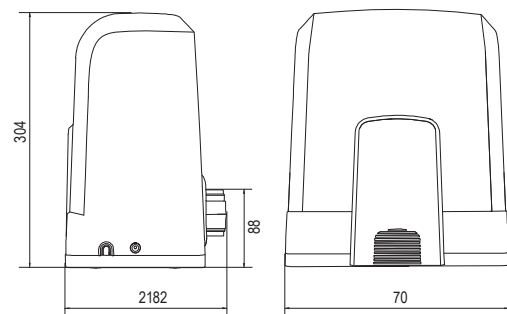

- |                     |   |
|---------------------|---|
| <b>SL1000EVK-01</b> | SL1000EVK-Kit<br>+ infrared + safety sensor (772E-01)                             |
| <b>SL1000EVK-02</b> | SL1000EVK-Kit<br>+ flashing light (FLA1LED)                                       |
| <b>SL1000EVK-03</b> | SL1000EVK-Kit<br>+ infrared safety sensor (772E-01)<br>+ flashing light (FLA1LED) |

